

7SP Controller Programmers

ADVANTAGE EZ Series 7SP 1/16 DIN Controller Programmer

- *Dual 4 Digit LED Display*
- *Universal Input (7 T/C, RTD, mV, V, mA)*
- *Autotuning*
- *NEMA 4X*
- *100 to 240 Vac Switching Power Supply*
- *One 4 Segment Program with Initial Wait*
- *Tracking and Guaranteed Soak Functions*
- *Up to 2 Independent Alarms Configurable with Automatic or Manual Reset*
- *Logic Input for Program Start*



The Advantage EZ 1/16 DIN Programmer provides fully configurable ramp/soak capability for applications where multiple setpoints, soak duration and controlled ramps are required.

Optional Features

- Relay or SSR Driver Output

Introduction

The Barber-Colman Series 7 establishes a new class of microprocessor based temperature controllers. As part of the Series 7 family, the 7SP is capable of one 4 segment program. Designed specifically for applications where guaranteed soak times are required, the 7SP allows ramp tracking, with the number of repeats and soak times to be configured. The 7SP is ideal for environmental chamber use where multiple temperature cycles are a requirement. NEMA 4X faceplates allow these units to be used in applications where washdowns and dust applications exist.

The 7SP is light and compact (1/16 DIN size). It is capable of a sophisticated response to the most demanding temperature control process. The 7SP is insensitive to noise, perfect in quality and able to adjust itself automatically to load variations or modified parameters.

Even operators without skills in temperature process control or knowledge of PID control parameters can obtain perfect control. For the best results in control stability, simply:

- Wire the instrument
- Configure the setpoint and alarm thresholds
- Initiate the autotune function

7SP Controller Programmers

Specifications

General

Case:	Polycarbonate grey. Self-extinguishing degree V-0 according to UL, VDE and CSA.
Front Protection:	Designed and tested for IP65 and NEMA 4X for indoor locations (when panel gasket is installed). Tested in accordance with IEC 529, CEI 70-1 and NEMA 250-191 STD.
Installation:	Panel mounting by means of brackets. Instrument removable from case by safety screw.
Rear Terminal Block:	Screw terminals with safety rear cover.
Dimensions:	48 x 48 mm (1.890 x 1.890 in) according to DIN 43700; 122 mm (4.803 in) depth.
Weight:	450 grams maximum (1 pound).
Power Supply:	(Switch Mode) from 100 to 240 Vac, 50/60 Hz (+10% to -15% of the nominal value) or 24 Vdc/Vac, $\pm 10\%$ of the nominal value).
Power Consumption:	8 VA
Insulation Resistance:	Less than 100 M Ω according to IEC 348.
Isolation Voltage:	1500 Vrms according to IEC 348.
D/A Conversion:	Dual slope integration.
Noise Immunity:	<ul style="list-style-type: none">- Electrical fast transient/burst requirements: Severity Level 3 (according to IEC 801-4).- Electrical discharge requirements: Severity Level 8 (according to IEC 801-2).
Common Mode Rejection Ratio:	120 dB @ 50/60 Hz.
Normal Mode Rejection Ratio:	60 dB @ 50/60 Hz.
Accuracy:	$\pm 0.2\%$ full scale value @ 25 °C and nominal power supply voltage.
Operating Temperature:	From 0 to 50 °C.
Storage Temperature:	-30 to 70 °C.
Humidity:	From 20 to 85% RH non-condensing.
Protection:	<ul style="list-style-type: none">- WATCH DOG for automatic reset.- DIP switches for configuration and calibration parameter protection.

Thermocouple Inputs

Type:	J, K, L, N, R, S and T are keyboard configurable. (All the inputs are factory calibrated and selectable by front keyboard.)
Engineering Units:	°C and °F keyboard configurable.
Line Resistance	
Compensation Error:	Max. $\pm 0.1\%$ of the input span with input impedance of 100 Ω .
Sensor Break	Downscale or upscale programmable.
Reference Junction:	Automatic compensation from 0 to 50 °C.
Reference Junction	
Drift:	0.1 °C/°C.
Input Impedance:	Less than 100 K Ω .
Calibration:	According to IEC 584-1.

7SP Controller Programmers

Specifications (continued)

Standard Ranges

TC Type	Range
L	0 to 400.0 °C
L	0 to 900 °C
J	0 to 400.0 °C
J	0 to 1000 °C
K	0 to 400.0 °C
K	0 to 1200 °C
N	0 to 1400 °C
R	0 to 1760 °C
S	0 to 1760 °C
L	0 to 1650 °F
J	0 to 1830 °F
K	0 to 2190 °F
N	0 to 2550 °F
R	0 to 3200 °F
S	0 to 3200 °F
T	0 to 750 °F

NOTE: For TC inputs, it is possible to set the minimum span to 300 °C or 600 °F, which makes it possible to increase the sensitivity of the control parameters.

RTD Input

RTD Type:	Pt 100 3 wire connection.
Calibration:	According to DIN 43760.
Line Resistance:	Max 20 Ω /wire with no measurable error.
Engineering Units:	°C and °F keyboard programmable.
Sensor Break:	A special test is provided to signal OVERRANGE when input resistance is less than 15 Ω (short circuit sensor detection).

Standard Ranges

°C	°F
-199.9 to 400.0 °C	-199.9 to 400.0 °F
-200 to 800 °C	-330 to 1470 °F

7SP Controller Programmers

Specifications (continued)

mAdc and Vdc Inputs

mAdc Input (Standard):	0 to 20 mAdc and 4 to 20 mAdc, keyboard programmable. Input Impedance: less than 3 Ω .
Vdc Input:	0 to 5 Vdc and 1 to 5 Vdc, programmable. Input impedance greater than 90 K Ω . 0 to 10 Vdc and 2 to 10 Vdc, programmable. Input impedance greater than 180 K Ω . 0 to 60 mVdc and 12 to 60 mVdc, programmable. Input impedance greater than 1 M Ω .
Readout:	Keyboard programmable from -1999 to 4000.
Decimal Point:	Programmable in any position.

Standard Ranges

Input	Impedance
0 to 20 mAdc	Less than 3 Ω
4 to 20 mAdc	Less than 3 Ω
0 to 60 mVdc	Greater than 1 M Ω
12 to 60 mVdc	Greater than 1 M Ω
0 to 5 Vdc	Greater than 90 K Ω
1 to 5 Vdc	Greater than 90 K Ω
0 to 10 Vdc	Greater than 180 K Ω
2 to 10 Vdc	Greater than 180 K Ω

Logic Input

Selects between SP1/SP2. Requires external contact with rating greater than 0.5 mA, 5 Vdc.

Control Action

Algorithm:	PID + Smart AT.
Type:	One control output.
Proportional Band:	Programmable from 1.0% to 100.0% of the input span.
Integral Time:	Programmable from 20 seconds to 20 minutes (or off).
Derivative Time:	Programmable from 1 second to 10 minutes (or off).
Integral Preload:	Programmable from 0 to 100% of the output range.
Out 1 Cycle Time:	From 1 to 200 seconds.
Standby/Manual Mode:	Selectable by front pushbutton.
Setpoint Limiters:	Setpoint low limit and setpoint high limit are programmable.

Control Outputs

Type:	Time proportioning.
Update Time:	250 ms.
Direct/Reverse Action:	Keyboard programmable.
Cycle Time:	Programmable from 1 second to 99 seconds.
Output Level Indication:	Shows percentage on the lower display.
Output Status Indication:	One indicator (OUT1) lit when the output is in ON condition.
Output Level Limit:	From 0 to 100%.
Output Relay:	SPST contact with rated current 4 Amps at 250 Vac on resistive load.
Logic Voltage for SSR Driver:	Logic Level 0: Less than 0.5 Vdc. Logic Level 1: 24 Vdc \pm 20% @ 1 mA 14 Vdc \pm 20% @ 20 mA

7SP Controller Programmers

Specifications (continued)

Alarms

This instrument is equipped with three independent outputs. The first one is used as the control output while the other two can be programmed as:

	Alarm 1 + Alarm 2
	Event 1 + Alarm 2
	Alarm 1 + "End-of-cycle"
	Event 1 + "End-of-cycle"
	Direct or reverse function programmable.
Alarm Functions:	Each alarm can be configured as process alarm, band alarm or deviation alarm.
Alarm Reset:	Automatic or manual reset programmable on each alarm.
Alarm Masking:	Each alarm can be configured as masked alarm or standard alarm.
Alarm Indications:	Two indicators lit when the respective alarm is ON.
Alarm Outputs:	Two SPST relays. Contact rated at 2 Amps at 250 Vac on resistive load.

Process Alarm

Operating Mode:	Minimum or maximum programmable.
Threshold:	Entered in engineering units within the entire range.
Hysteresis:	Programmable from 0.1% to 10.0% of the input span.

Band Alarm

Operating Mode:	Inside or outside programmable.
Threshold:	Programmable from 0 to 500 units.
Hysteresis:	Programmable from 0.1% to 10.0% of the input span.

Deviation Alarm

Operating Mode:	High or low programmable.
Threshold:	Programmable from -500 to 500 units.
Hysteresis:	Programmable from 0.1% to 10.0% of the input span.

Event

When OUT 2 is used as an Event output, during program execution it will assume the status (ON or OFF) programmed for the segment being executed.

End-of-cycle Indication

When OUT 3 is used as an "end-of-cycle" indicator, at the end of every program repetition cycle it will be forced to the ON status for 10 seconds.

7SP Controller Programmers

Features

Series 7SP Programmer Worksheet

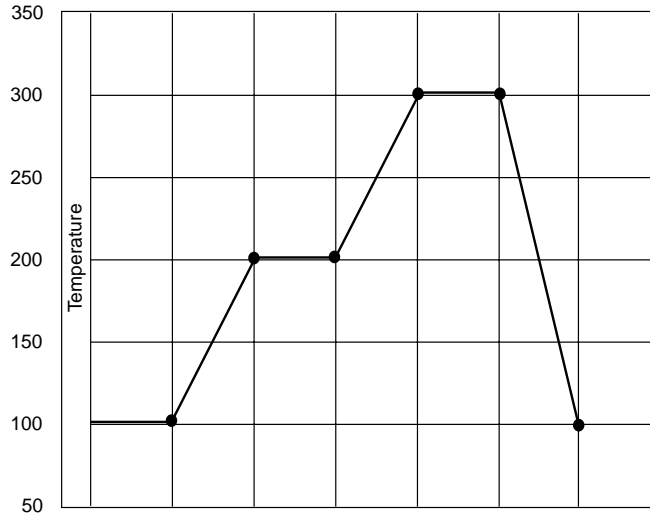

SP# STEP	Step Number	1	2	3	4	5	6	7
DEL4	Wait Time (hh:mm)	02:00						
SP1	End Setpoint 1		200					
GRD1	Rate of Ramp to SP 1		5					
tin1	Soak Time (hh:mm)			06:30				
SP2	End Setpoint 2				300			
GRD2	Rate of Ramp to SP 2				10			
tin2	Soak Time (hh:mm)					32:00		
rpt	Number of Program Repetitions						2	
DEL4	Wait Time on Repetition						02:30	

Logic Input (The 7SP is equipped with a logic input used to start the program execution.)

Setpoint Pattern - Segments Description

- Standby:** The device operates as an indicator. The power output is OFF and alarms are in the "no alarm" condition.
Range: From 0 to 99 hours 59 minutes.
- WAIT:** In this segment the power output is OFF and alarms are in the "no alarm" condition. The time duration of this segment is programmed by the "WAIT TIME" parameter. The upper display shows the process variable while the lower display flashes the time to reach the end of this segment.
Range: From 0 to 99 hours 59 minutes.
- RAMP TO SPx:** At the beginning of this segment, the instrument aligns the operating setpoint to the measured value and starts ramping towards SPx (SP1 or SP2). The upper display shows the process variable while the lower display shows the setpoint. The gradient of this ramp is programmable. During ramp execution the tracking function may be activated.
Range: From 1 to 100 digits/minute or step transfer.

7SP Controller Programmers

Features (continued)

4. SOAK to SPx:

In this segment, the guaranteed soak feature may be activated. The upper display shows the process variable while the lower display shows the time to reach the end of this segment.

Range: From 0 to 99 hours 59 minutes.

Manual Mode

When the instrument is in the MANUAL mode the lower display shows "m" followed by the OUT 1 power value (from 0 to 100%). The power output can be modified using the ▼ and ▲ keys.

NOTE: If a shutdown occurs when the instrument is in the MANUAL mode, at instrument powerup it will restart in MANUAL with the same power output assigned to the instrument before the power shutdown.

Operator Interface

Keyboard Description

FUNC

- During parameter modification the new setting of the selected parameter is stored and the next parameter is displayed (in increasing order).
- During program execution or when operating as a controller (without a program), pressing the FUNC key for more than 3 seconds will show "H." on the lower display, followed by the OUT 1 power (from 0 to 100%). Press the FUNC key again, and the display will return to the "normal display mode."

RUN

- With P9 = 0 and the instrument in STANDBY, press RUN for 1 second to start program execution.
- With P9 = 0, press for 5 seconds to abort the program.
- During parameter modification RUN is used to scroll back the parameters without saving the new setting.

▲

- Increases the selected parameter during parameter modification.
- Allows direct access to the setpoint when the instrument is operating as a controller.
- Increases the output when the instrument is in the manual mode.

▼

- Decreases the selected parameter during parameter modification.
- Allows direct access to the setpoint when the instrument is operating as a controller.
- Decreases the output when the instrument is in the manual mode.

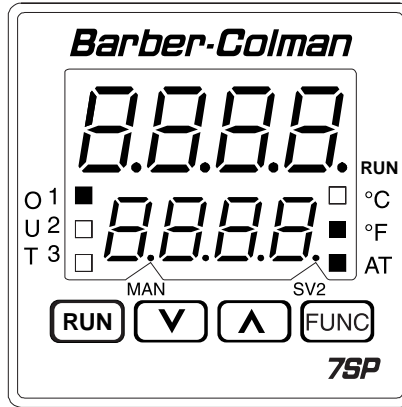

Keyboard Description (continued)

▲ + **FUNC**

Toggles between STANDBY and MANUAL mode.

▲ + **FUNC**
or
▼ + **FUNC**

Increases or decreases the the selected parameter at a faster rate.

▲ + **▼**

When Autotuning (Smart AT) is disabled, the up and down arrow keys are used to start the default parameter loading procedure.

Upper Display

Shows the actual measured value or the selected parameter value.

Lower Display

- In standby mode shows "OFF"
- In manual mode shows the output level.
- During parameter modifications it shows the abbreviated name of the selected parameter.
- In the RUN mode it shows:
 - the operating setpoint when the instrument is performing a ramp.
 - the remaining soak time when the instrument is performing a soak.

Indicators

°C Lit when the process variable is in degrees Celsius.

°F Lit when the process variable is in degrees Fahrenheit.

AT Lit when the Smart AT algorithm is active.

OUT1 Lit when OUT 1 is ON.

OUT2 Lit when OUT 2 (used as an event output) is ON or Alarm 1 is in alarm condition.

OUT3 Lit when Alarm 2 is in alarm condition or OUT 3 is used as a logic output "end-of-cycle" and is showing the end of a cycle.

SV2 Lit when SP2 is operating.

MAN Flashes when the instrument is in MANUAL mode.

RUN Lit when program is running. Flashes when program execution is stopped by tracking or guaranteed soak functions.

7SP Controller Programmers

Operator Interface (continued)

Guaranteed Soak

The Guaranteed Soak feature assures that the product receives adequate process time at all required setpoints. Internal comparators continually verify that process values are within acceptable ranges and only decrement timers when acceptable values are found.

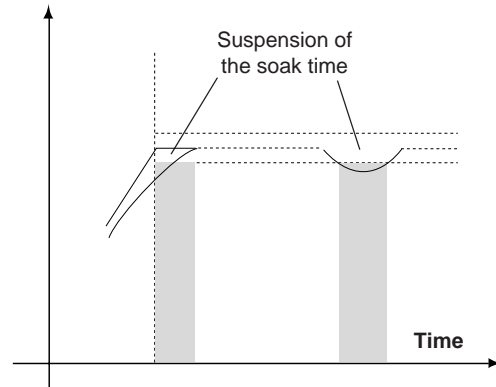

Ramp Tracking

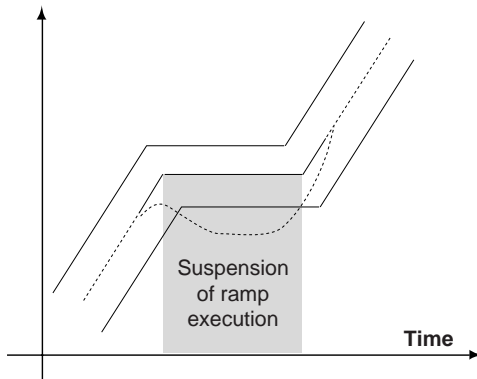

The Ramp Tracking feature is used during a ramping condition. If the process is upset, the controller will seek to apply the ramp after the process stabilizes.

Four Segment Program

A single four segment program is available which can be repeated from 1 to 100 times. Separate delay segment can be defined for the first step and all "wait" steps after a repeat.

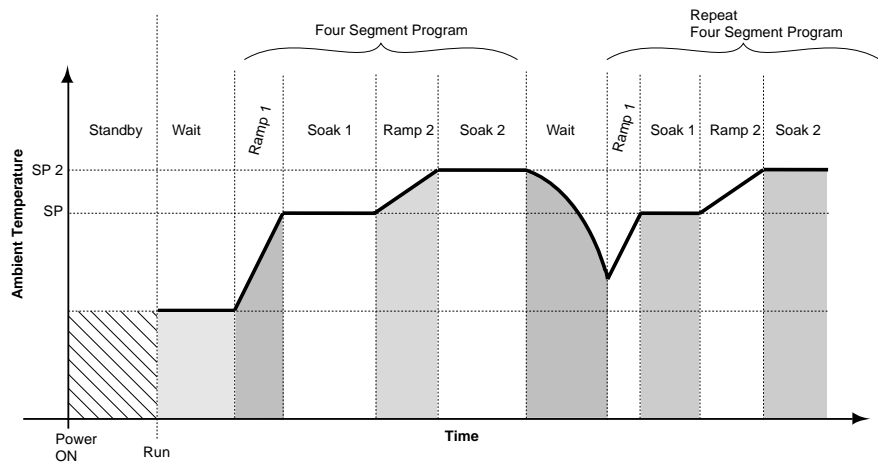

7SP Controller Programmers

Operator Interface (continued)

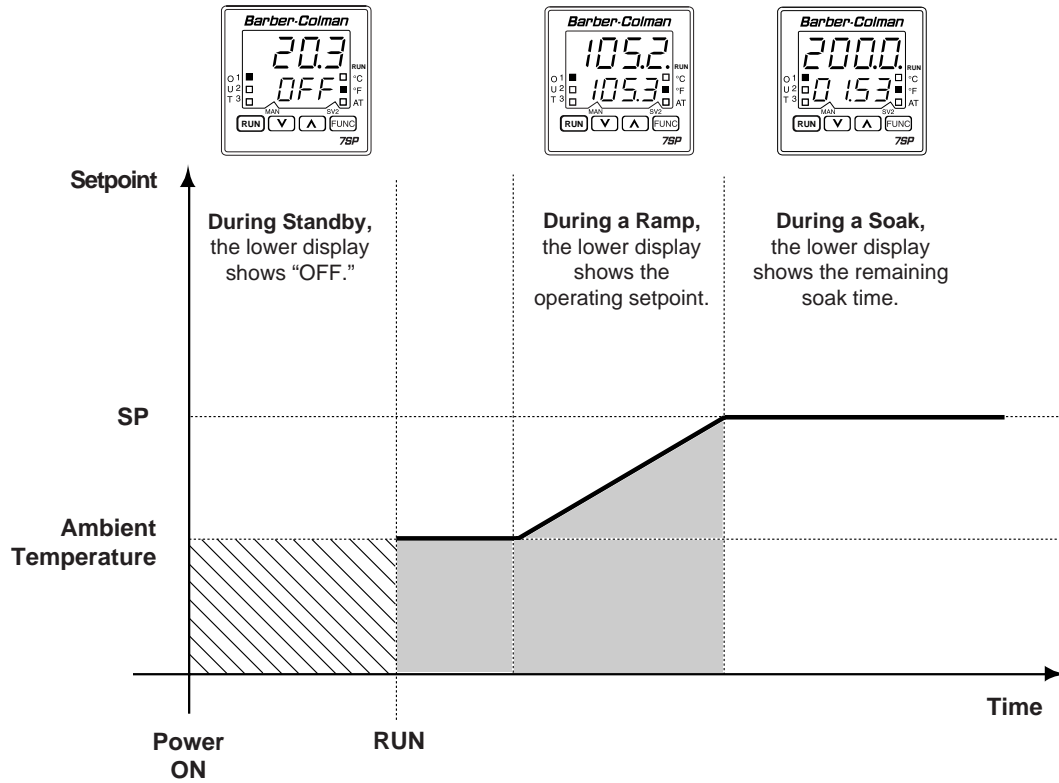

7SP Controller Programmers

Wiring

Rear Terminal Block

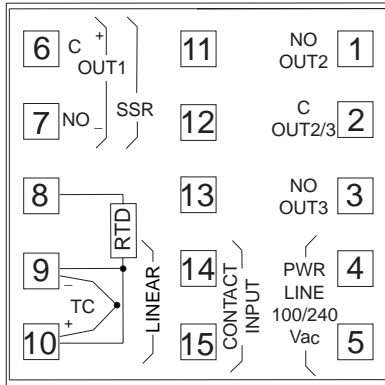

Input Wiring

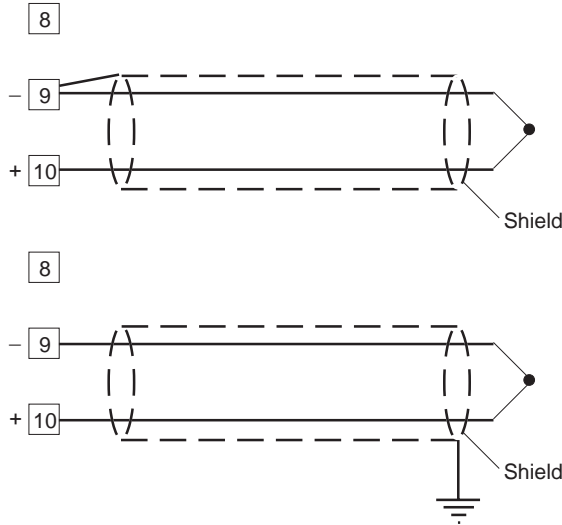

Thermocouple Input Wiring

NOTE: Do not run input wires together with power cables. For TC wiring use proper compensating cable, preferably shielded. If shielded cable is used, it should be grounded at one point only.

Power Line Wiring

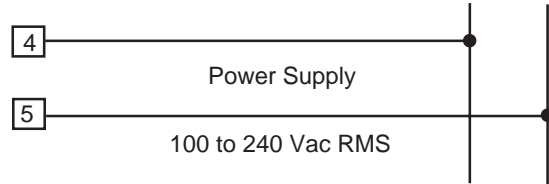

NOTE: To avoid electric shock, connect power line at the end of the wiring procedure.

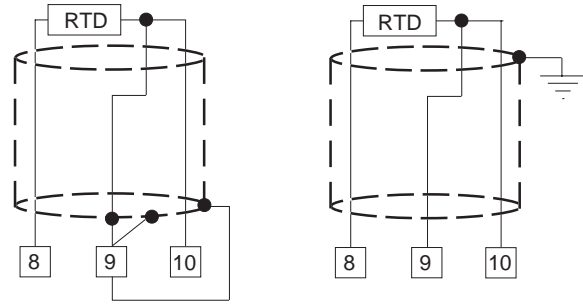

NOTE: Do not run RTD wires together with power cables. If shielded cable is used, it should be grounded at one point only. Use copper wires of appropriate size (see "Product Specifications"). The resistance of the 3 wires must be the same.

Any external components (like zener diodes, etc.) connected between sensor and input terminals may cause errors in measurement due to excessive or unbalanced line resistance, or possible leakage currents.

Logic Input

Safety note:

- Do not run logic input wiring with AC power cables.
- Use an external contact with a contact rating greater than 0.5 mA, 5 Vdc.
- The instrument needs 100 ms to recognize a change in contact status.

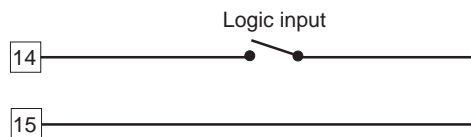

This input selects between SP and SP2 as the operating setpoint.

7SP Controller Programmers

Wiring (continued)

OUTPUTS

RELAY OUTPUTS

Relays are protected by a varistor. The contact rating for OUT 1 is 3 Amps/250 Vac on a resistive load. The contact rating for OUT 2 and OUT 3 is 2 Amps/250 Vac on a resistive load.

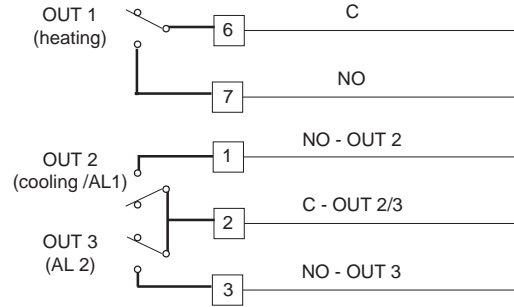

Relay Output Wiring

INDUCTIVE LOADS

High voltage transients may occur when switching inductive loads. These transients may introduce disturbances which can affect the performance of the instrument. The internal varistor assures protection up to 0.5 Amp of inductive component of the load. The same problem may occur when a switch is used in series with the internal contacts. In this case, it is recommended to install an additional RC network across the external contact as shown.

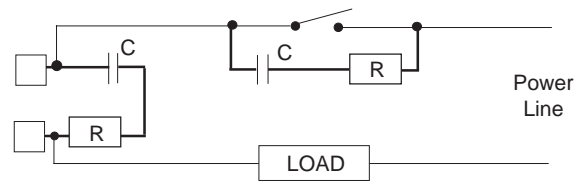

External Switch in Series with the Internal Contact

The value of capacitor (C) and resistor (R) are shown in the following table.

Load Current	R (Ω)	C (μ F)	Resistance Power (W)	Resist. and Capac. Voltage
Less than 150 mA	22	0.1	2	260
Less than 0.5 Amp	47	0.33	2	260
Less than 1 Amp	47	0.47	2	260

Relay output wiring must be as far away as possible from input or communication cables.

VOLTAGE OUTPUTS FOR SSR DRIVE

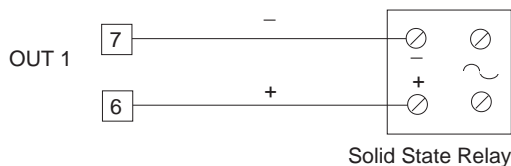

SSR Drive Output Wiring

Logic voltage for SSR drive (time proportioning).

- Logic status 1: 24V \pm 20% @ 1 mA
14 V \pm 20% @ 20 mA
- Logic status 0: Less than 0.5 V

NOTE: This output is not isolated. Isolation between instrument output and power supply must be assured by the external solid state relay.

See "Controller Mounting Dimensions" at the end of this section.