



Compact Solid State Power Controller Delivers Big Performance



The Watlow[®] DIN-A-MITE[®] Style A power controller provides a low-cost, highly compact and versatile solid state option for controlling electric heat. You also get all the quality you expect from a Watlow designed and manufactured product. DIN-rail and back panel mounting is standard on every controller. There is no need to worry about mercury, the DIN-A-MITE controller is mercury free.

Capabilities include single-phase zero cross switching up to 25 amps at 600V~(ac) (see rating curve). A unique integrated design removes the guesswork associated with selecting a proper heat sink and adequate terminations for the application.

Variable time base, 4-20mA process control or V~(ac/dc) input contactor versions are available. All configurations are model number dependent and factory selectable.

The DIN-A-MITE power controller is made in the United States.

Watlow[®] and DIN-A-MITE[®] are registered trademarks of Watlow Electric Manufacturing Company.
UL[®] and C-UL[®] are registered trademarks of the Underwriter's Laboratories, Inc.

Your Authorized Watlow Distributor Is:

Features and Benefits

200KA Short Circuit Current Rating (SCCR)

- Prevents arc flash

DIN-rail or standard panel mount

- Versatile, quick and low-cost installation

Compact size

- Reduces panel space; less cost

Touch-safe terminals

- Increases safety for installer/user

No mercury

- Environmentally safe product

Faster switching with solid state

- Saves energy and extends heater life

UL[®] 508 listed, C-UL[®] and CE with filter

- Meets applications requiring agency approval

Back-to-back SCR design

- Insures a rugged design



Registered Company
Winona, Minnesota USA



Specifications

Operator Interface

- Command signal input
- Input indicator light LED

Amperage

- Single phase, see the output rating curve
- Max. I²t for fusing: 4000A²sec
- Latching current: 200mA
- Holding current: 100mA
- Power dissipation is 1.2 watts per amp switched
- 200KA SCCR, Type 1 and 2 approved with the recommended fusing; see user manual.

Line Voltage

- 20 to 660V~(ac) model number dependent; see ordering information
- Off-state leakage: 1mA at 25°C (77°F) max.
- 50/60Hz independent

Control Mode-Zero Cross

- Input control signal Type C: V=(dc) input contactor
- Input control signal Type K: V~(ac) input contactor
- To increase service life on contactor input models, the cycle time should be less than three seconds
- Input Control Signal Type F: 4 to 20mA=(dc) proportional variable time base control

Input Command Signal

- AC contactor
24V~(ac) ±10 percent, 120V~(ac) +10/-25 percent, 240V~(ac) +10/-25 percent @ 25mA max. per controlled leg
- DC Contactor
4.5V= to 32V=(dc): max. current @ 4.5 V=(dc) is 8mA per leg
- Loop powered linear current
4mA= to 20mA=(dc): loop-powered, input Type F0 option only (requires current source with 6.2V=(dc) available, no more than three DIN-A-MITE inputs can be connected in series)

Agency Approvals

- UL® 508-listed and C-UL® File E73741
- CE with proper filter:
89/336/EEC Electromagnetic Compatibility Directive
73/23/EEC Low Voltage Directive
EN 61326 Industrial Immunity Class A Emissions
EN 50178 Safety Requirements

Input Terminals

- Compression: will accept 0.2 to 2 mm² (24 to 14 AWG) wire

Line and Load Terminals

- Compression: will accept 0.8 to 8.4 mm² (18 to 8 AWG) wire

Operating Environment

- Up to 80°C (176°F); see the output rating curve chart for your application
- 0 to 90% RH (relative humidity), non-condensing
- Installation only tested to 3,000 meters
- Units are suitable for "Pollution degree 2"

Mounting

- Options include DIN-rail or standard back panel mounting
- The DIN-rail specification is: DIN EN 50022, 35 mm by 7.5 mm
- Mount the cooling fins vertically

Dimensions

- Height: 95 mm (3.7 in.) high x 45 mm (1.8 in.) wide x 98 mm (3.9 in.) deep
- Weight: 0.32kg (0.71 lb)

Specifications are subject to change without notice.

Ordering Information

To order, complete the code number on the right with the information below.

DIN-A-MITE Style A = Solid State Power Controller

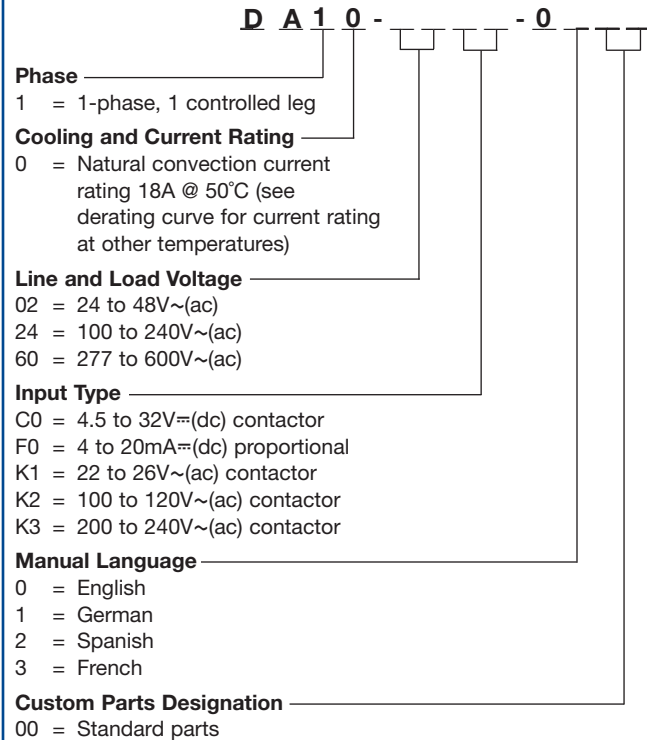

Recommended Semiconductor Fuse and Fuse Holder

	Watlow	Cooper Bussmann®	Ferraz Shawmut
Fuse	17-8025	FWC25A10F	L330014
Holder	17-5110	B24202	G81219

Output Rating Curve

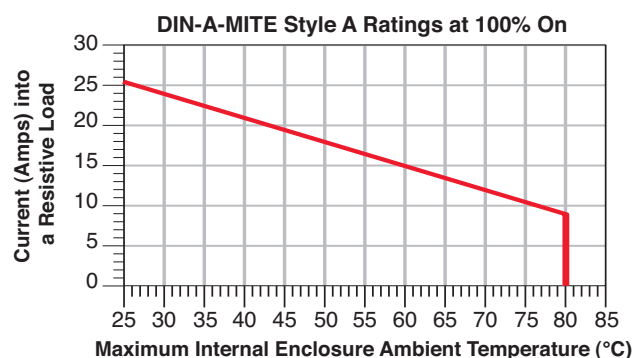

Cooper Bussman® is a registered trademark of Cooper Bussman, Inc.

To be automatically connected to the nearest North American Technical Sales Office:

1-800-WATLOW2 • www.watlow.com • info@watlow.com

International Technical Sales Offices: Australia, +61-3-9335-6449 • China, +86-21-3950-9510 • France, +33 (0) 3073-2425 • Germany, +49 (0) 7253-9400-0 • Italy, +39 (0) 2 458-8841 • Japan, +81-3-3518-6630 • Korea, +82-2-575-9804 • Malaysia, +60-3-7980-7741 • Mexico, +52 (442) 217-6235 • Shanghai, +86-21-3950-9504 • Singapore, +65-6777-1266 • Spain, +34 91 675 1292 • Sweden, +46 35-27-11-66 • Taiwan, +886-7-288-5168 • United Kingdom, +44 (0) 115-964-0777